

# Experimental Quantum Computing: A technology overview

Dr. Suzanne Gildert  
Condensed Matter Physics Research (Quantum Devices Group)  
University of Birmingham, UK  
15/02/10



UNIVERSITY OF  
BIRMINGHAM

# Brief overview:

## Models of quantum computation

## Implementations

Ion traps

Optical photons / Neutral atoms

NMR

Superconducting circuits

Nanomechanical resonators

## Example of operation

The Bloch sphere

The density matrix

## Decoherence + limitations

The DiVincenzo criteria

Measuring T1 and T2

Sources of decoherence



UNIVERSITY OF  
BIRMINGHAM

# What is a quantum computer?

There are different definitions, but when people say Quantum Computer they usually mean Universal Quantum Computer.

Most quantum algorithms require superposition of states, entanglement of bits, and phase coherence to obtain universality.

There are other types of *special purpose* systems which exploit one or more, but not all of these features. (i.e. they use some features of Quantum Mechanics in their operation but cannot solve all the problems which a universal system could).

I will spend most of the time discussing this universal variety.



A transistor obeys the laws of quantum mechanics (in fact everything does!) so why aren't Pentium 4's quantum computers? What's the difference?

A quantum system has to be controllable – i.e. you have to be able to isolate and manipulate the quantum information.



UNIVERSITY OF  
BIRMINGHAM

# 'Models' of QC

Gate model /circuit model QC

Cluster state (measurement-based) QC

Adiabatic QC

Topological QC

You can think of these as a bit like different architectures.  
All have been shown to be universal (think Turing machine) and therefore theoretically equivalent in computational power.

Here I will focus on the 'gate model'

- It is the easiest to understand in terms of quantum information and also the most widely implemented



# The Gate model

The basic premise of the gate (or circuit) model:

You apply Unitary operators to your quantum system one by one.

So the diagrams of quantum circuits map directly to the hardware:

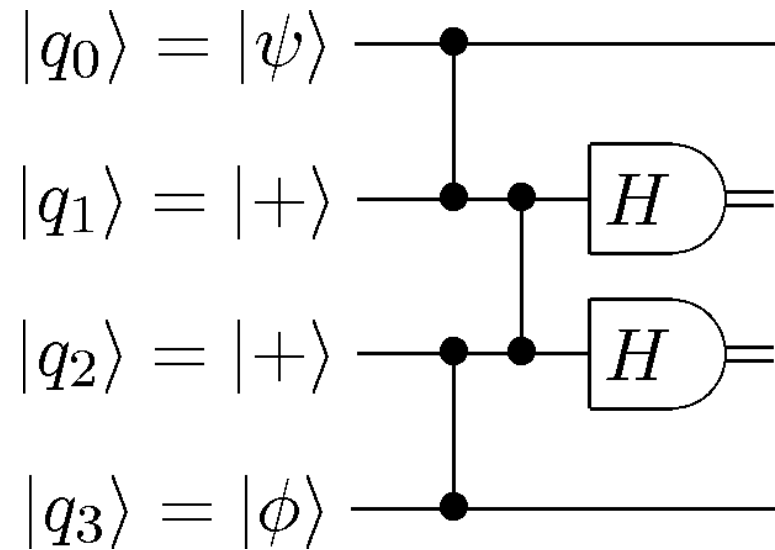
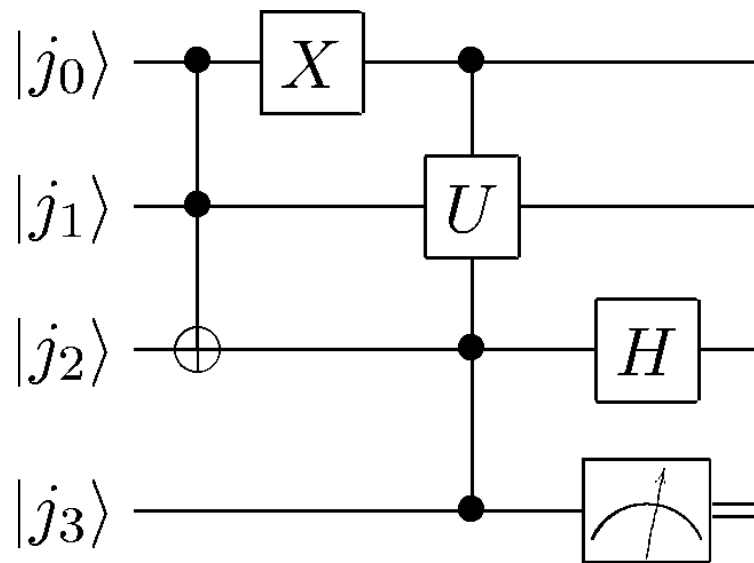

# Implementations

Within each model there are different ways to realise the computer (implementations).

What do you physically require? All implementations effectively realise the following:

A controllable two-level system (n-level?)  
Also known as an 'artificial atom'

There are many different systems in which this can be realized.

I will now describe a few, and their advantages and disadvantages.

Natural and artificial atoms for quantum computation  
Iulia Buluta, Sahel Ashhab, and Franco Nori  
arXiv:1002.1871

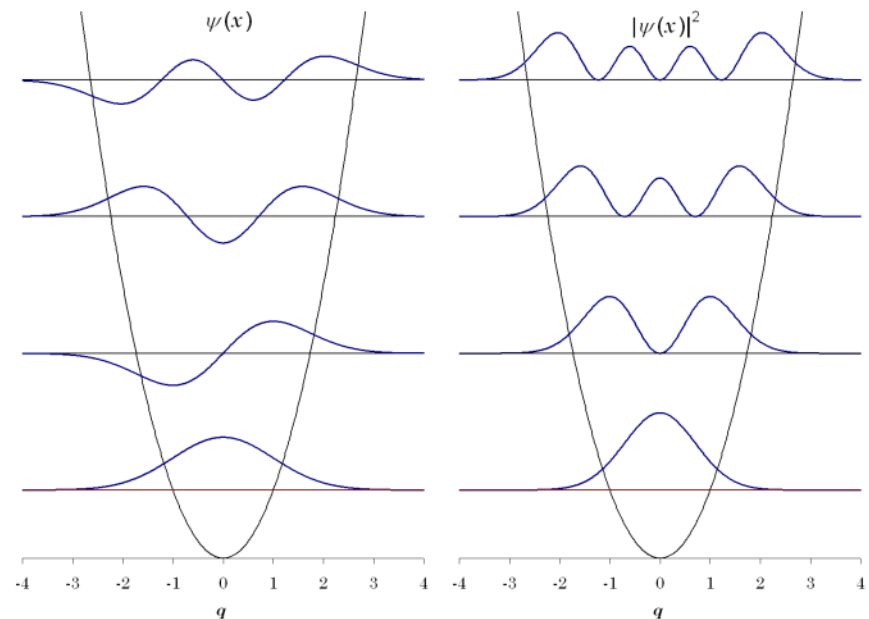
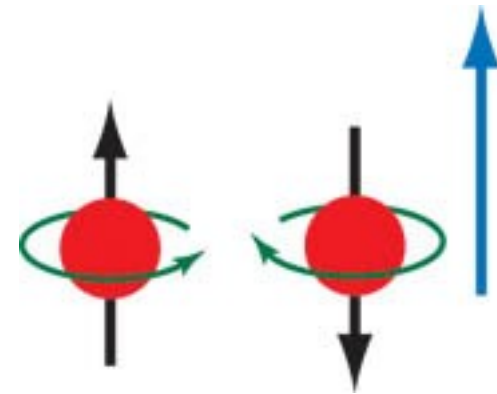

# Ion traps

Ions interact strongly via the Coulomb interaction, and can be trapped by electrical (or magnetic) fields

Quantum information encoded either hyperfine / Zeeman levels, / ground and excited states of an optical transition / motional states.

## Long coherence times -

Hyperfine transitions  $> 10$  minutes

Initialization of the qubits can be done by optical pumping. Measurement via laser-induced fluorescence

**High-fidelity 1, 2 and 3 qubit gates** have been experimentally demonstrated, in addition to entangled states.

**Scalability proposals** include ion shuttling (Apply RF and DC fields to move the ions around on the chip), two-dimensional ion arrays, photon interconnections, long equally-spaced strings, and two-dimensional Coulomb crystals.

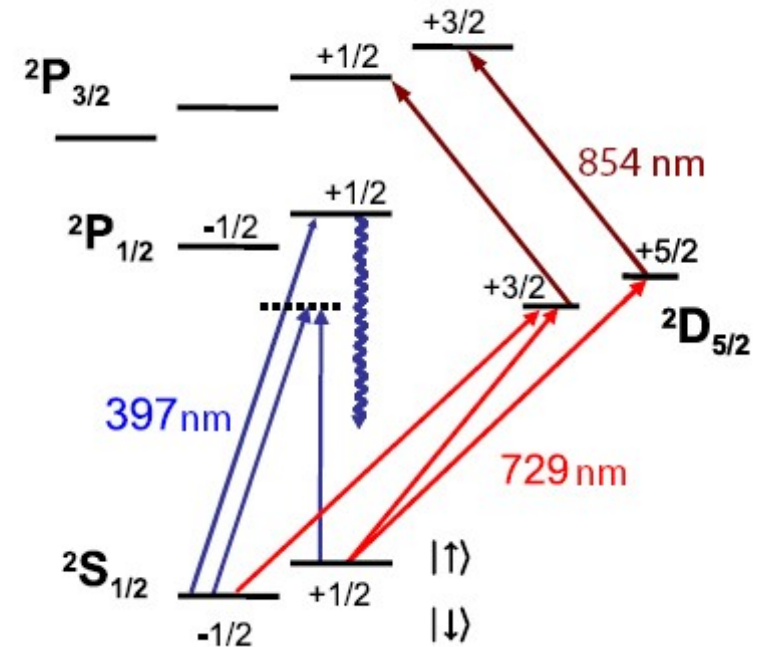

[http://arxiv.org/PS\\_cache/arxiv/pdf/0902/0902.2826v2.pdf](http://arxiv.org/PS_cache/arxiv/pdf/0902/0902.2826v2.pdf)



UNIVERSITY OF  
BIRMINGHAM

# Ion traps

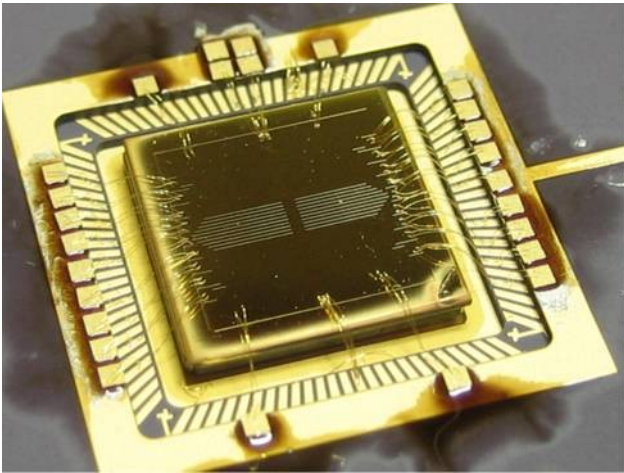
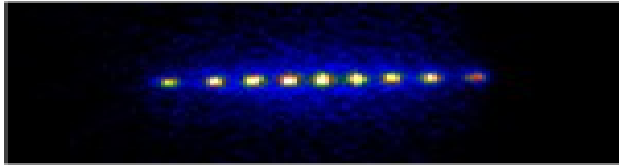

ion-to-surface distance is 150 microns, vibrational frequency for trapped Ca ions is 3.5 MHz

<http://www.physics.ox.ac.uk/users/iontrap/>

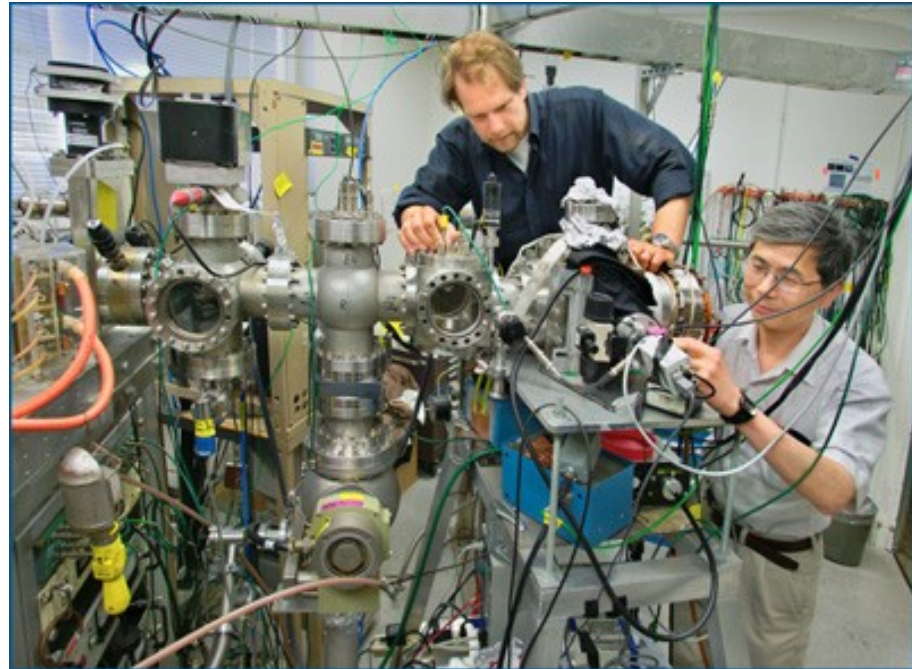

<http://www.lbl.gov/Science-Articles/Archive/sabl/2005/June/02-quantum-comp.html>



UNIVERSITY OF  
BIRMINGHAM

# Optical Photonic systems and Neutral Atoms

The qubits encoded in the atomic energy levels

Initialized by optical pumping and laser cooling

Manipulated with electromagnetic radiation

Measured via laser-induced fluorescence

Weak interaction with the environment, long coherence times.

Very recently, a CNOT has been demonstrated using these systems

(Dr. Boyer will discuss these topics in more detail)



# Nuclear Magnetic Resonance

IBM's prototype NMR computer consisted of a molecule with 7 qubits (Fluorine and Carbon atoms).

The qubits are initialised, manipulated and read out using magnetic fields and magnetic spectroscopy.

This group of atoms behaves as a set of coupled spins. Each coupling has a unique energy spectrum, so can be addressed by fine-tuning the applied field.

The 7 qubit machine can run Shor's algorithm for factoring numbers.

Famous for factorising 15

Graphics:

<http://domino.watson.ibm.com/comm/pr.nsf/pages/rscd.quantum-pica.html/>

Photo by Volker Steger/Science Photo Library

Nuclear magnetic resonance (NMR) spectrometer at the TU München

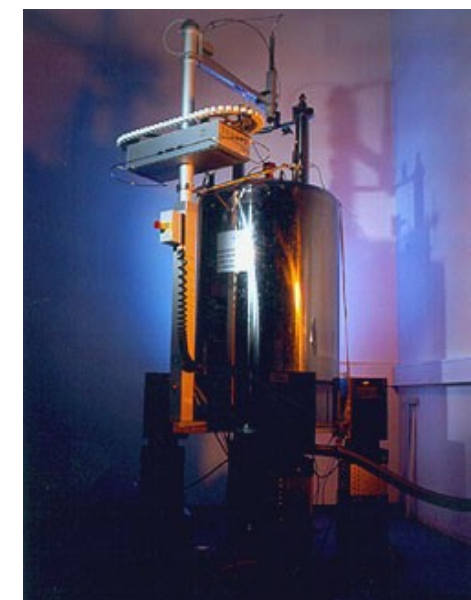
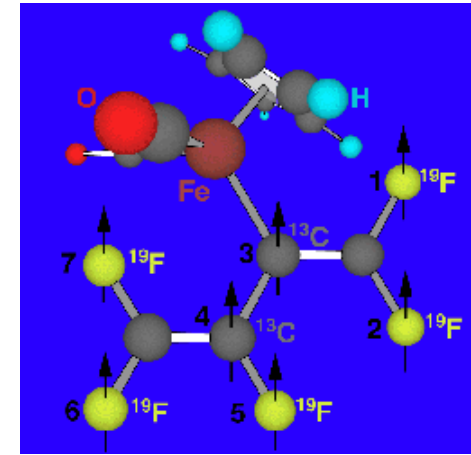

UNIVERSITY OF  
BIRMINGHAM

# Superconducting qubits

(my own work is in this field)

Loops of superconducting metal (usually Nb or Al) - Several 'varieties'

**Charge qubits** – the charge degree of freedom of the electron encodes the quantum state  
(Eigenstates: Number of electrons)

**Phase qubits** – the phase of the electron wavefunction is the quantum variable  
(Eigenstates: Energy levels in a well)

**Flux qubits** – the flux basis  
(Eigenstates: Direction of flux/spin)

Decoherence times  $\sim$  ns – us

Advantage: Can be made using standard semiconductor processing techniques

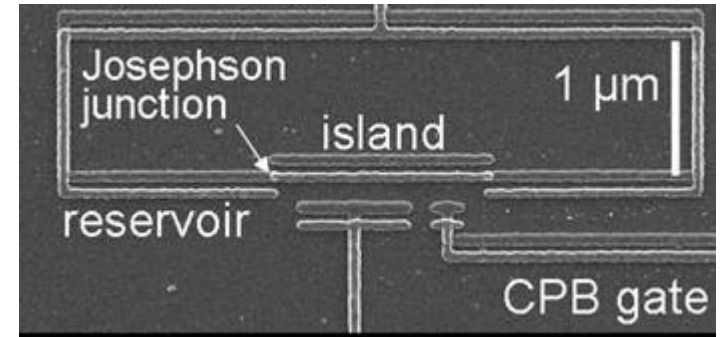

<http://www.lps.umd.edu/>

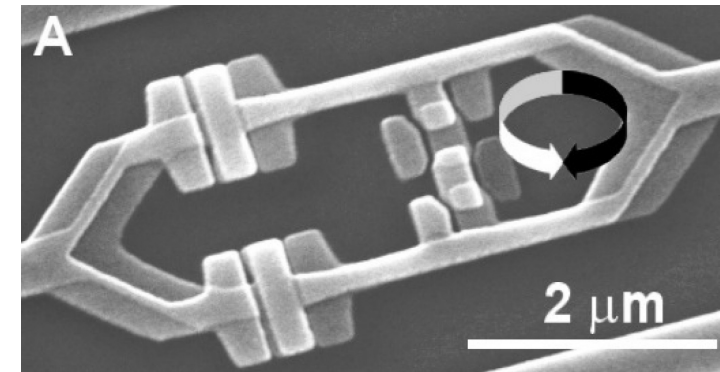

Graphic:  
TU Delft

S/C qubits must be cooled to  $\sim$ 10mK in temperature



UNIVERSITY OF  
BIRMINGHAM

# Nano-mechanical resonators and qubits

An interesting idea – the ground state motion of a small mechanical resonator can encode quantum information

The information can be swapped between resonator and photon via an inductive coupling.

The use of mechanical structures in quantum computation.

Hamiltonian is very similar to that of an atom interacting with a single mode of the electromagnetic field: cavity QED

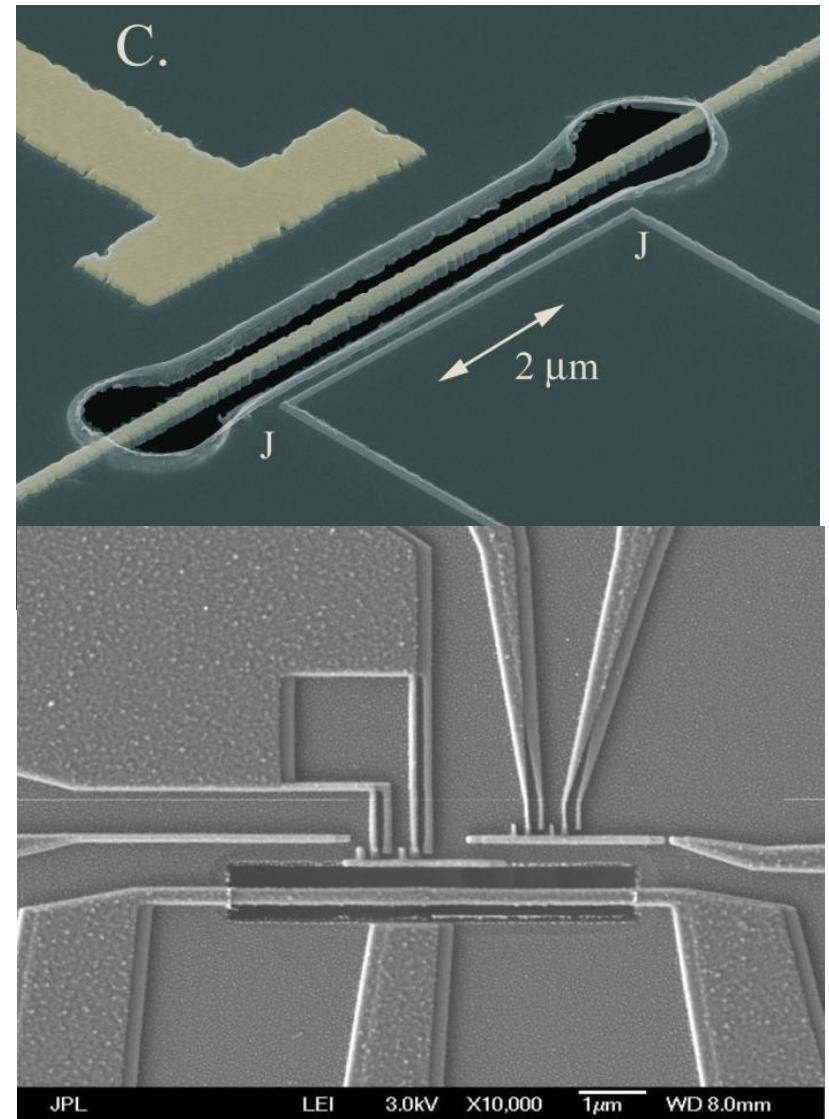

How do you physically manipulate the quantum state of such a system?



UNIVERSITY OF  
BIRMINGHAM

# Example: Flux qubit

(states are represented by which well you are in)

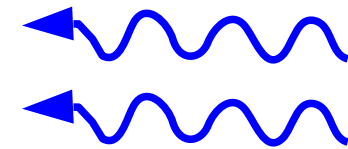
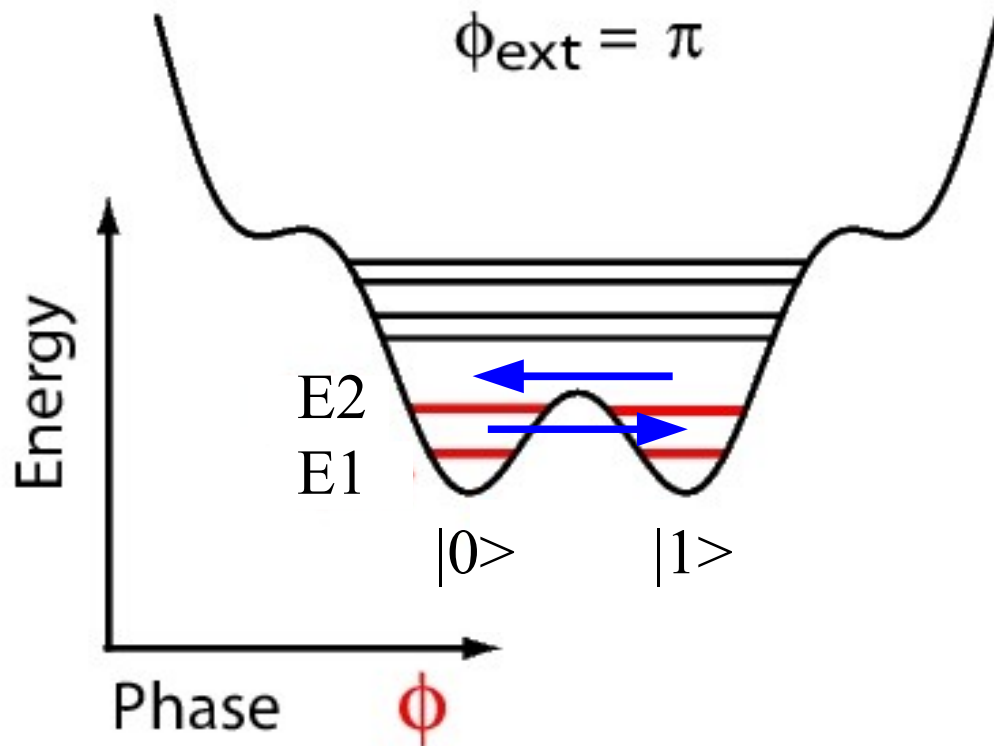

Apply microwaves to the system at the resonant frequency  $E_2 - E_1$

Qubit slowly evolves from state  $|0\rangle$  to state  $|1\rangle$  through mixed states inbetween, such as  $1/\sqrt{2}(|0\rangle + |1\rangle)$



# The Bloch sphere (an experimentalist's point of view)

You can apply pulses of different duration to bring you to different places on the Bloch sphere.

E.g. a  $\pi/2$  pulse will take you from  $|0\rangle$  to  $1/\sqrt{2}(|0\rangle+|1\rangle)$

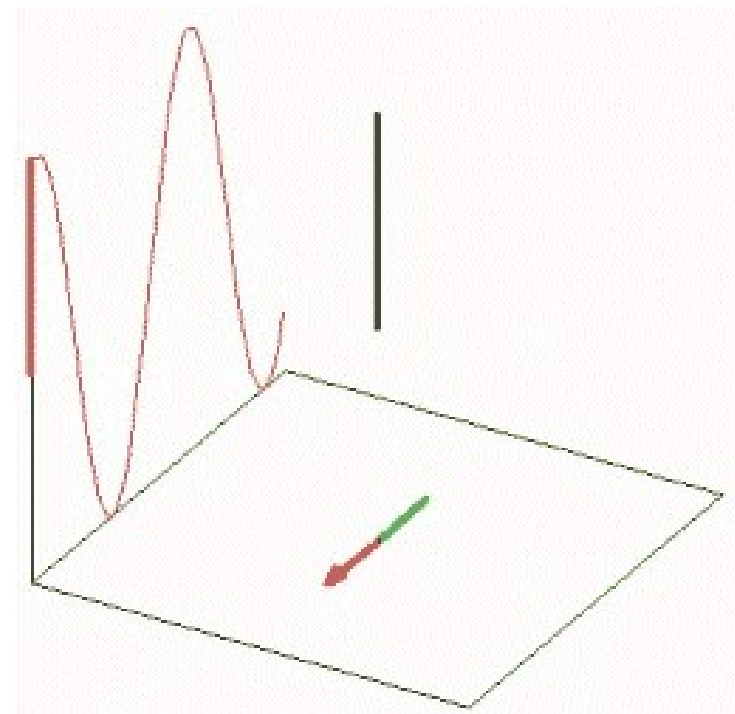
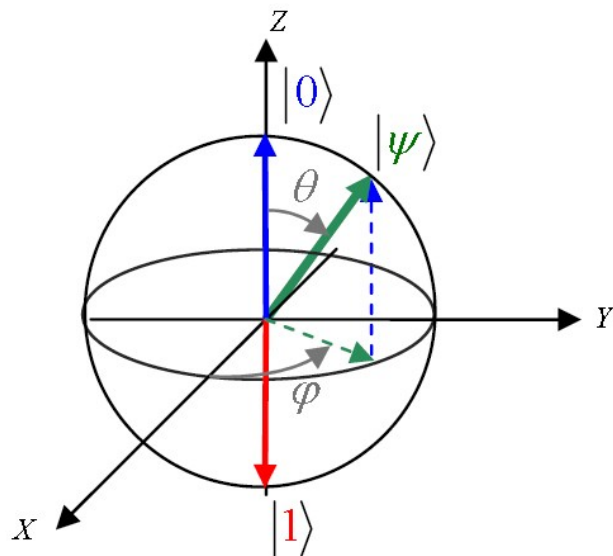

Graphic from  
<http://thermowiki.epfl.ch/tqi/particle-spin>



UNIVERSITY OF  
BIRMINGHAM

# The density matrix (an experimentalist's point of view)

By applying different pulses in this way, you can move around the Bloch sphere and implement single qubit gates.

Implementing entangling operations is also possible with multiple qubits coupled together.

State tomography gives you an experimental view of the density matrix of a system.

Apply different rotations and stochastically compile the results

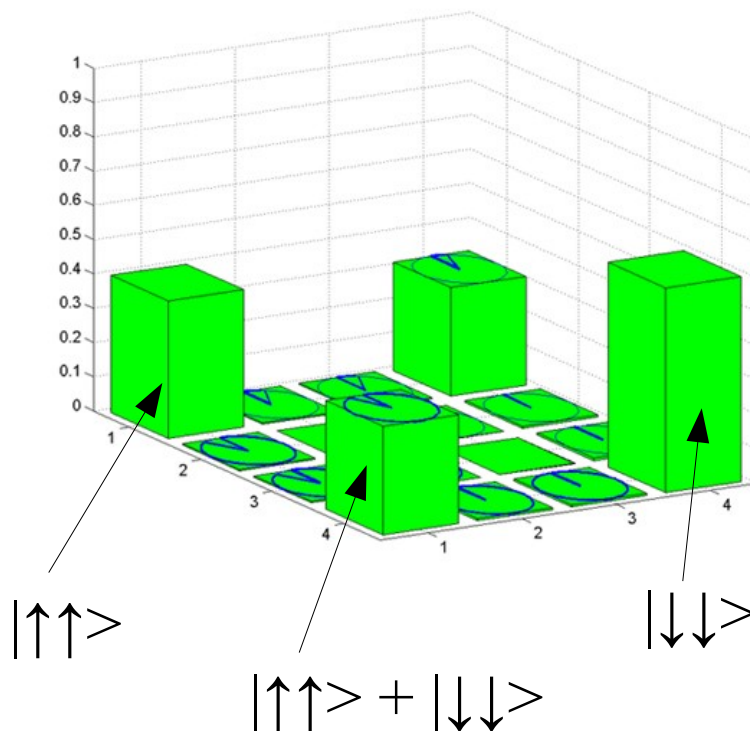

Deterministic entanglement of two Calcium-40 ions in a Paul trap with 82(2)% fidelity – from <http://www.physics.ox.ac.uk/users/iontrap/news.html>



# Things experimentalists worry about when building QCs:

## DiVincenzo criteria

1. Be a scalable physical system with well-defined qubits
2. Be initializable to a pure state such as  $|000\dots\rangle$
3. Have long (enough) decoherence times
4. Have a universal set of quantum gates
5. Permit high quantum efficiency, qubit-specific measurements

So for example, photonic systems are very long lived quantum states (long  $T_2$ ) but they are not as scalable as solid state systems.



# Decoherence in real systems

## Energy relaxation (T1)

If you are using 2 energy states to represent information, any physical system will 'relax' towards the ground state given enough time.

## Dephasing/decoherence (T2)

The phase information becomes spread out / lost.

Usually  $T2 \ll T1$

Relaxation  
processes

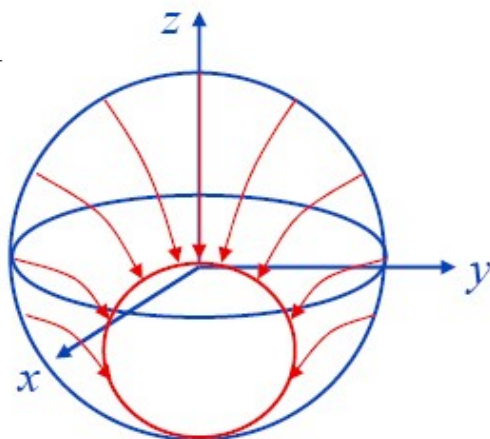

Dephasing  
processes

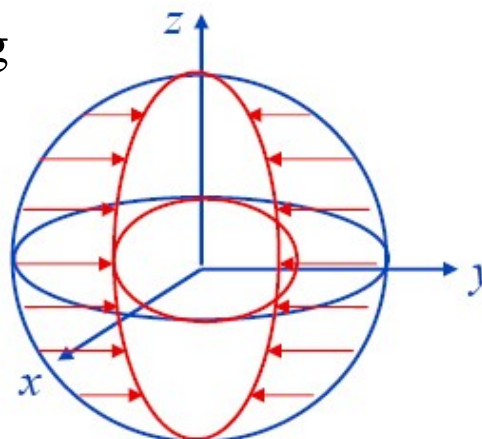

# Experimental tests of relaxation and decoherence:

**Rabi Oscillations** measure T1:

Apply pulses of fixed time delay and compile statistics of the state moving from  $|0\rangle$  to  $|1\rangle$

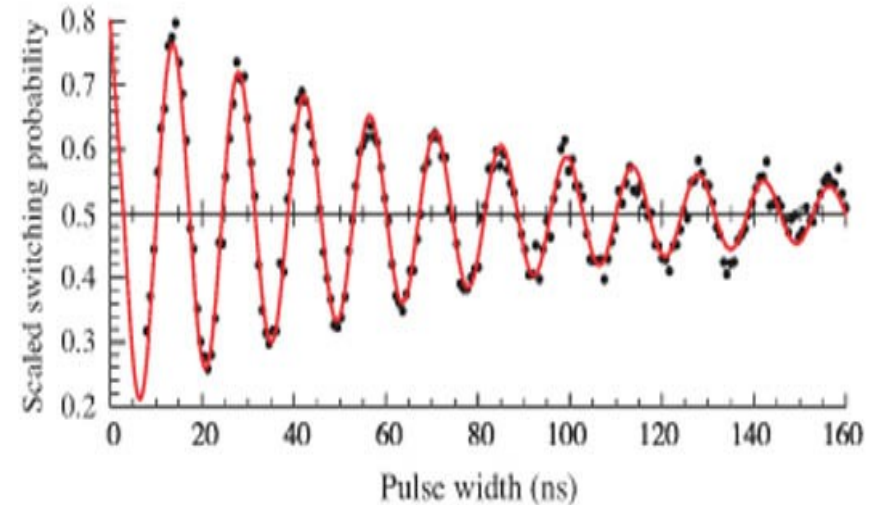

**Spin Echo technique** to measure T2:

Apply pi pulses in a particular sequence to cause a phase rotation which should bring the state back to where it started. Dephasing can be seen by the pulse losing clarity.

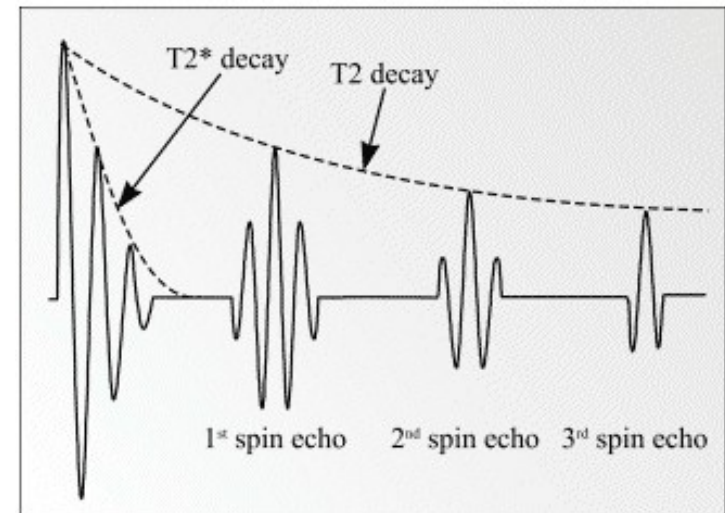

# What causes decoherence?

## Intrinsic and Extrinsic sources

Any source which couples (can transfer energy) to your quantum system.

### Extrinsic:

Magnetic and electrical stray fields

Radio wave interference

Mechanical vibration

### Intrinsic:

Temperature of the system

Material defects (charge centres, trapped magnetic particles)

Some systems e.g. solid state implementations are much more sensitive to these sources as the qubits are large.

In most quantum computing systems, extrinsic noise has been reduced to below the level of intrinsic effects. So the qubits are now limited by the materials technologies.

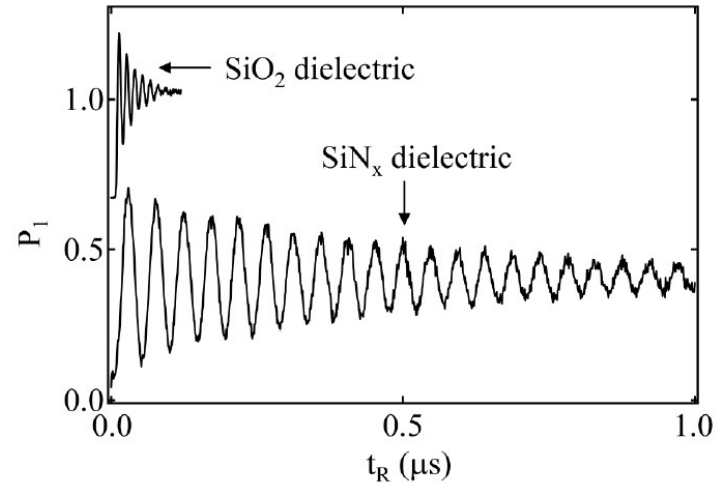

Dielectric matters!

**Simmonds et al., PRL 93 (2004)**

**Martinis et al., PRL 95 (2005)**



UNIVERSITY OF  
BIRMINGHAM

# Further reading:

Nielsen & Chuang, Chapter 7 (realizations)

Caltech nanomechanical resonators:

<http://www.kschwabresearch.com/>

Oxford Ion Trap group:

<http://www.physics.ox.ac.uk/users/iontrap/>

Natural and artificial atoms for quantum computation

I. Buluta et al. ArXiv:1002.1871

Syracuse University (Plourde group)

<http://physics.syr.edu/~bplourde/>

Coherent Manipulation of a  $^{40}\text{Ca}^+$  Spin Qubit in a Micro Ion Trap

U. G. Poschinger et al. arXiv:0902.2826

Contact: Dr. Suzanne Gildert

Blog 'Physics and Cake' - <http://physicsandcake.wordpress.com>



UNIVERSITY OF  
BIRMINGHAM